



3

360 D/A - converter

User manual



Dear client

We are proud that you have chosen a solution D/A-converter. In doing so, you have acquired an audio component of outstanding quality with exceptional sonic performance which we are sure you will enjoy for many years to come.

It is important that you study this user manual carefully, step by step, before you install the 360 D/A-converter in your audio system. The manual contains information on how the 360 D/A-converter works, relevant safety instructions and recommendations for optimizing your entire audio system.

If you have any questions regarding the installation, setup or operation of your 360 D/A-converter, please do not hesitate to contact your dealer.

Enjoy!

solution Team



CE-Declaration of Conformity

Spemot AG declares that this product conforms to the following directives and standards:

Low Voltage Directive 2014/35/EU

Electromagnetic Compatibility 2014/30/EU

FCC-Notice

Note: This equipment has been tested and found to comply with the limits for a Class B digital device, pursuant to Part 15 of the FCC Rules. These limits are designed to provide reasonable protection against harmful interference in a residential installation. This equipment generates, uses and can radiate radio frequency energy and, if not installed and used in accordance with the instructions, may cause harmful interference to radio communications. However there is no guarantee that interference will not occur in a particular installation.

If this equipment is found to cause unwanted or harmful interference to radio or television reception when switching on or off, the user is encouraged to take one or more of the following measures:

- adjust or relocate the receiving antenna of the affected appliance
- increase the separation between the equipment and the receiver
- connect the equipment into a mains outlet on a circuit different from that to which the receiver is connected
- consult your dealer or an experienced radio/TV technician for help

Disposal

According to Directive 2012/19/EU of the European Parliament, consumer electro-technical appliances must display the following symbol and must be disposed of separately. In the event of this component requiring disposal please do so in conformity with all locally applicable legal and environmental regulations.





Table of contents

1	Highlights	4
2	Safety advice:	4
3	Scope of delivery	6
4	Setup.....	6
5	Rear and front view	7
6	Connections	8
7	Operation	10
8	Configuration	12
9	Remote control	15
10	Firmware Update	16
11	Troubleshooting.....	17
12	Service	17
13	Specification	18
14	Dimensions.....	18



1 Highlights

1.1 Power supply

A switched mode power supply followed by fast-switching DC-DC converters and low noise linear regulator provide the required supply voltages for the 360 D/A-converter. Switched mode power supplies provide supply voltages that are more stable and lower in noise than other power supply technologies.

1.2 DAC

With its 4 digital inputs (SPDIF, AES/EBU, Network, USB) provides connectivity to a wide selection of digital sources. A powerful DSP converts all incoming digital music signals to the DXD format, performs the zeroPhase processing and the LEEDH volume control. One PCM1792 in mono configuration per channel takes care of the digital to analog conversion of the music signals. The internal digital filtering of the chip is bypassed for optimal results. The passive reconstruction filter sports custom made high precision components ensuring stable filter characteristics, prerequisite for a perfect compensation with the zeroPhase technology.

1.3 Output stage

The powerful output stage (max 0.2A) can also drive long connecting cables to amplifiers easily. The wide bandwidth design (> 5MHz, -3dB) ensures lowest phase shifts in the audio band.



2 Safety advice:

User manual	<ul style="list-style-type: none">⇒ Follow the safety advice⇒ Keep this user manual
Mains supply	<p>3 phase power cords with a ground conductor are mandatory. Unplug the 360 from the mains:</p> <ul style="list-style-type: none">⇒ before you adjust or manipulate mains cables⇒ before cleaning the unit⇒ during thunderstorms⇒ when leaving the unit unused for longer periods
Cabling	<p>Unplug the 360 from the mains while connecting or disconnecting interconnect cables. Incorrect cabling may cause damage to your 360, your audio system, or loudspeakers. Excessive volume due to inappropriate handling may cause hearing damage.</p>
Transport	<p>Use only the cart, stand, tripod, bracket or table specified by the manufacturer or sold with the apparatus. When a cart is used, take care when moving cart/apparatus combination to avoid injury or tipping over.</p>
Packing	<p>To avoid the formation of water condensation within the 360, allow it to reach room temperature before unpacking it. Keep the original packing safely for future transport requirements.</p>
Operation	<p>Never run your 360</p> <ul style="list-style-type: none">⇒ whilst the casing is open⇒ with obstructed cooling slots⇒ in high ambient temperatures (>40 °C)⇒ in proximity to heat sources like radiators, etc.⇒ in areas of extreme humidity (for example in a humid cellar)⇒ close to water (sink, bathtub, taps or similar facilities)
Cleaning	<p>Use a soft and dry towel. We suggest using a nonabrasive microfiber towel. Please do not use any solvents or liquids.</p>
Service	<p>Service by a qualified person will be required if</p> <ul style="list-style-type: none">⇒ the mains cable or the mains connectors are damaged⇒ foreign substances or liquids have entered the 360⇒ if the 360 has been rained on⇒ the 360 exhibits any form of malfunction⇒ the 360 has been dropped⇒ if the casing is damaged



3 Scope of delivery

- ⇒ 360 D/A - converter
- ⇒ IR remote control
- ⇒ Mains cable
- ⇒ Spare fuses
- ⇒ User manual
- ⇒ Set of shims

Please check the scope of delivery. If anything is missing or you notice any damage while unpacking, please contact your authorised dealer.

4 Setup

Remove the 360 D/A - converter carefully from the cardboard boxes and position it on a stable surface in an appropriate location ensuring cooling air can circulate and escape unhindered. Do not cover the surface of the 360 D/A - converter with a cloth or any other object as the complete chassis acts as a heat sink.

The feet of the 360 D/A - converter feature a constrained layer damping system which will mitigate vibrations away from the unit. The damping system is designed to work on any surface material. The feet shims are used in case the surface of your audio rack is not perfectly in level.

For best results we suggest using a dedicated audio rack system for all of your audio components.



5 Rear and front view

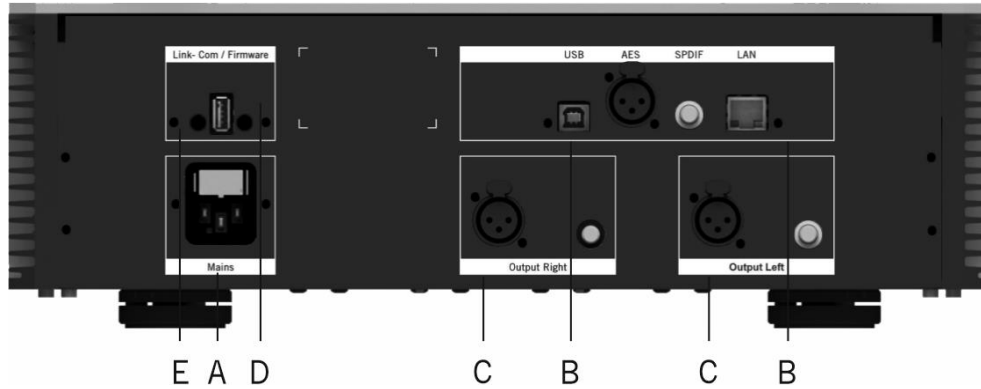

Rear view of the 360 D/A - converter

- | | |
|-------------------------|-------------|
| A) AC mains input | D) Link-com |
| B) D/A converter inputs | E) Firmware |
| C) Output | |

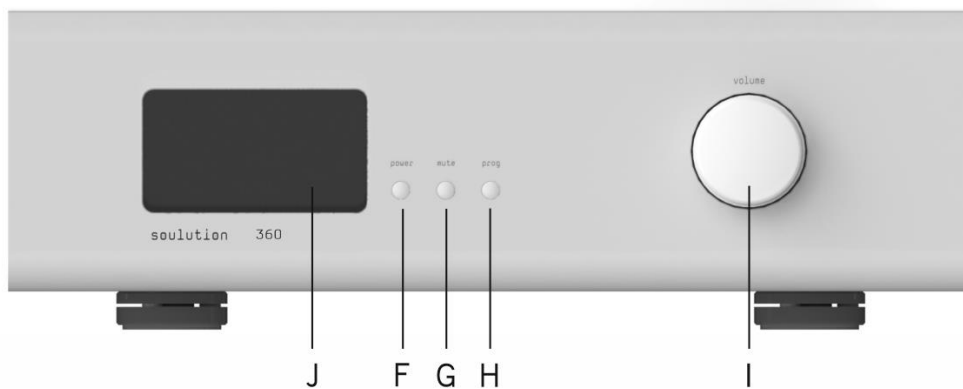

Front view of the 360 D/A - converter

- | | |
|-----------------|-----------------------|
| F) power button | I) Rotary knob |
| G) mute button | J) Display and IR eye |
| H) prog button | |



6 Connections

6.1 AC mains input (A)

Connect the 360 D/A - converter to the mains supply. Please use a high-quality power cable for optimal sonic results. The 360 has no power switch. The device will enter standby mode as soon as it is connected to the mains supply.



unplug mains

Unplug the unit from the mains supply when

- ⇒ left unused for longer periods
- ⇒ adjusting the wiring of your audio system
- ⇒ during thunderstorms
- ⇒ Set the 360 to standby before unplugging it from the mains.

6.2 D/A-converter inputs (B)

The digital-to-analog converter features network, USB, SPDIF and AES/EBU inputs. A powerful DSP converts all digital signals to DXD, the zerophase technology ensures minimal phase errors along signal path.

AES/EBU and SPDIF

File format	Bit depth	Sampling rate
PCM (WAV, AIFF, FLAC, etc.)	16 - 24 bit	32 – 192 kHz
DSD (DoP)	1 bit	2.82 – 5.64 MHz

USB

The readable file formats depend mainly on the used player software. The following formats can be received by the 360's USB input:

File format	Bit depth	Sampling rate
PCM (WAV, AIFF, FLAC, etc.)	16 - 24 bit	32 – 192 kHz
DSD (DoP)	1 bit	2.82 – 5.64 MHz



The 360's USB input supports USB Audio Class 2.0. For operating systems such as Mac OS X, it supports driver free playback up to 24bits/192kHz. Under Windows 8 and lower a specific USB Audio Class 2.0 driver is required for playback of files with sampling rates > 96kHz.

Network

The 360's network input will be recognized as „UPnP™ AV/DLNA Media Renderer device“ and can be accessed from your media server.

File format	Bit depth	Sampling rate
FLAC (Free Lossless Audio Codec)	16-24 bit	44.1 – 192 kHz
WAV (Waveform Audio File Format)	16-24 bit	44.1 – 192 kHz
MP3 (Mpeg Audio Layer 3)	16-24 bit	44.1 – 192 kHz
ALAC (Apple Lossless Audio Codec)	16-24 bit	44.1 – 192 kHz
AAC (Advanced Audio Coding)	16-24 bit	44.1 – 192 kHz
AIFF (Audio Interchange File Format)	16-24 bit	44.1 – 192 kHz
DSF and DFF (DSD stream file)	1 bit	2.82 – 5.64 MHz
DXD (Digital eXtreme Definition)	24 bit	352.8 kHz

6.3 Output (C)

Due to the exceptional load stability there are no restrictions regarding the selection of your connecting cables. For long cable lengths we recommend using balanced cables.

6.4 Link-Com (D)

The Link-Com interface will turn-on/off connected components.

6.5 Firmware (E)

The USB input is provided for firmware updates only. For detailed instructions please refer to section 10 Firmware Update.



7 Operation

7.1 Power (F)

The power (H) button turns on the 360 D/A converter. The start-up sequence takes a short while as the power supplies for the different sections of the circuit are initiated. Progress will be reported in the display (J). Once the unit is ready to operate it will show the active input and volume level in the display (J).



Standby



Power-up squence



Ready to operate

If the 360 D/A - converter is on, the power (H) button will put the unit back into standby (power consumption <1W).

7.2 Mute (G)

The mute (G) button disconnects or reconnects all outputs from the analog circuits of 360 D/A - converter.

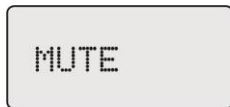

Mute

7.3 Prog (H)

The 360 D/A -converter can be configured to suit the individual requirements of your audio system. Pressing the prog (J) button (de)activates the configuration menus.



7.4 Rotary knob (I)

The multi-purpose rotary knob is used to control the volume, select the input, dim the volume, and to select the configuration menus of the 360 D/A - converter.

Operation-Mode



Turning the rotary knob (N) changes the volume.



short

Pressing the rotary knob for less than 1 second (de)activates the Volume-Dim function.



long

Pressing the rotary knob for more than 1 second activates the Input select mode.



Turning the rotary knob while the unit is in input select mode will in/decrement the input.

Configuration mode



Turning the rotary knob (N) selects the desired configuration function.



Pressing the rotary knob (N) confirms the selected configuration function and activates the value range (3 LEDs lit).



Turning the rotary knob (N) selects the desired value.



Pressing the rotary knob (N) confirms the new value.

7.5 Display (J)

Normal mode

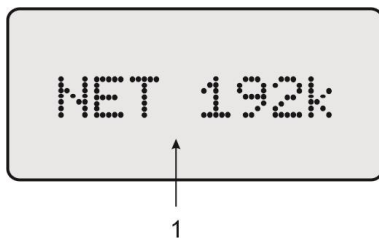

- 1) Selected input: SPDIF, AES/EBU, USB, NETWORK

Configuration mode

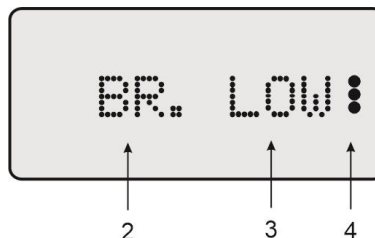

- 2) Configuration function
- 3) Value of function
- 4) LEDs are lit whilst values are changeable



8 Configuration

Function	Values	Remarks
<div style="border: 1px solid gray; padding: 2px; width: fit-content; margin-bottom: 5px;">PWR-MODE</div> <p><u>Power-Mode:</u> Defines start-up behaviour</p>	<div style="border: 1px solid gray; padding: 2px; width: fit-content;">PWR-NORM :</div>	Power-up with power-button, default value
	<div style="border: 1px solid gray; padding: 2px; width: fit-content;">PWR-LINK :</div>	360 waits for external LINK Signal
	<div style="border: 1px solid gray; padding: 2px; width: fit-content;">PWR-AUTO :</div>	Switches on automatically as soon as mains voltage is active.
<div style="border: 1px solid gray; padding: 2px; width: fit-content; margin-bottom: 5px;">START-IN</div> <p><u>Start-Input:</u> Defines active input after switch-on</p>	<div style="border: 1px solid gray; padding: 2px; width: fit-content;">S-IN S/P</div>	Start-Input: S/P default value
	<div style="border: 1px solid gray; padding: 2px; width: fit-content;">S-IN NET :</div>	Start-Input: Network
<div style="border: 1px solid gray; padding: 2px; width: fit-content; margin-bottom: 5px;">D-FILTER</div> <p><u>Digital Filters:</u> Selects the upsampling filter</p>	<div style="border: 1px solid gray; padding: 2px; width: fit-content;">D-F LIN</div>	LIN: Linear phase
	<div style="border: 1px solid gray; padding: 2px; width: fit-content;">D-F MIN</div>	MIN: Minimal phase
	<div style="border: 1px solid gray; padding: 2px; width: fit-content;">D-F LINA</div>	LINA: Linear phase with apodizing Default value
	<div style="border: 1px solid gray; padding: 2px; width: fit-content;">D-F MINA</div>	MINA: Minimal phase with apodizing
<div style="border: 1px solid gray; padding: 2px; width: fit-content; margin-bottom: 5px;">PHASE-EQ</div> <p><u>Phase-EQ:</u> (de) activates the zero-Phase technology</p>	<div style="border: 1px solid gray; padding: 2px; width: fit-content;">P-EQ ON</div>	ON: zeroPhase technology is active default value
	<div style="border: 1px solid gray; padding: 2px; width: fit-content;">P-EQ OFF</div>	OFF: zeroPhase technology not active
<div style="border: 1px solid gray; padding: 2px; width: fit-content; margin-bottom: 5px;">VOL-MODE</div> <p><u>Volume Mode:</u> (de) activates volume control</p>	<div style="border: 1px solid gray; padding: 2px; width: fit-content;">VOL LEED</div>	LEEDH control default value
	<div style="border: 1px solid gray; padding: 2px; width: fit-content;">VOL OFF</div>	Volume mode OFF



Function	Value	Remarks
S-VOLUME <u>Start-Volume:</u> Defines the volume level after switch-on	S-VOL 10 :	Minimal Start-Volume
	S-VOL 30 :	Default value
	S-VOL 40 :	Maximal Start-Volume
MAX-VOL <u>MAX-Volume:</u> Limits the volume level	M-VOL 40 :	Minimal MAX-Volume
	M-VOL 65 :	Suggested MAX-Volume
	M-VOL 90 :	Default value
DIM-VOL <u>DIM-Volume:</u> Defines the volume level of the DIM function	D-VOL 10 :	Default value
	D-VOL 10 :	Default value
	D-VOL 40 :	Maximal DIM-Volume
BALANCE <u>Balance:</u> Defines level difference between left and right channel	BAL <-9	Balance 9dB left
	BAL 0	Balance center (OFF) Default value
	BAL ->9	Balance 9dB right
POLARITY <u>Polarity</u>	POL 0 :	Polarity in phase, Default value
	POL 180 :	Polarity 180°, inverted



Function	Value	Remarks
BRIGHTHN. <u>Brightness:</u> Defines the brightness of the display	BR. LOW :	Low
	BR. MID :	Mid
	BR. HIGH :	High, Default value
REMOTE <u>Remote-ID:</u> Defines the Remote-ID for the 360.	REM DAC :	Default value
	REM Pre1 :	The 360's Remote-ID can be changed. Ensure that the ID of the remote control gets changed accordingly (see chapter 9)
	REM OFF :	
DEFAULT <u>Default-Values</u> Activates the default values for all functions.	LOAD NO :	No action
	LOAD YES :	Loads the default values.
	DONE	
FIRMWARE	FW-00001	Firmware version
	REV-0047	Firmware revision



9 Remote control

Button	Pre-Mode	CD-Mode
(1) IR-transmitter	Operation until 5m distance and angel of $\pm 45^\circ$.	
(2,3) ▲ ▼	Volume +/-	
(4) DIM / ►	Volume-Dim	Play/Pause
(5/6) ◀ ▶	Select +/-	Next / Previous track
(7) ←	Enter Function for Program-Mode	
(8) P	(De)activates Program-Mode	
(9) 🔊	Mute	-
(10) ⏻	ON / OFF	
(11) 🔼	-	Open/Close
(12) PRE	-	Activates PRE-Mode
(13) CD	Activates CD-Mode	-

Change of Remote Ctrl ID:

Press the respective buttons for approx. 5 seconds.

- ⇒ Pre 1: ◀ (6), ▶ (5), ⏻ (10)
- ⇒ Pre 2: ◀ (6), ▶ (5), 🔊 (9)
- ⇒ Phono ◀ (6), ▶ (5), ← (7)
- ⇒ DAC ◀ (6), ▶ (5), P (8)

Exchange of batteries (2 x AAA):

- ⇒ Open the battery tray on the rear side.
- ⇒ Insert the batteries into the tray as indicated.
- ⇒ Ensure correct polarity of the batteries.
- ⇒ Close the tray with corresponding screw.
- ⇒ Dispose the exhausted batteries





10 Firmware Update

USB-Stick:

The firmware of all soulution products can be updated via the USB port on the back panel. To update firmware, please prepare a USB stick (FAT32 formatted, UBS2.0) containing the required firmware data.

You can find the latest firmware for your 360 D/A - converter on our website www.soulution-audio.com. Unzip the downloaded .zip file and copy the firmware files to the root directory of the USB stick. Make sure there are no other files or folders on the USB drive.

Update-process:

- ⇒ Prepare the USB stick with the firmware files (no other files should be present).
- ⇒ Unplug the unit from the mains supply.
- ⇒ Insert the USB stick into the USB interface "Firmware".
- ⇒ Connect the unit to the mains supply.
- ⇒ Follow any instructions in the display.
- ⇒ Once the new firmware has been successfully loaded, the 360 D/A - converter will be in standby mode.
- ⇒ Power up the 360 D/A - converter.
- ⇒ After the 360 has completed its start-up sequence, press the prog key.
- ⇒ Select configuration function LOAD-DEFAULT and confirm with YES.
- ⇒ Configure the 360 D/A - converter to suit your requirements.



11 Troubleshooting

No Display	Check the mains connection, the fuse of your house installation, the fuse of the 360 D/A - converter and the brightness function. For the DISPLAY-OFF setting, the display is switched off during operation.
No music	<ul style="list-style-type: none">⇒ Check the cabling of your audio system⇒ Check whether the correct input is selected⇒ Check whether the source component is muted
PSU FAIL...	The 360 monitors all necessary supply voltages. If a supply voltage fails, the 360 will switch itself to MUTE with the corresponding error code shown in the display.

12 Service

If you cannot identify or rectify a fault by following the troubleshooting measures, please disconnect the 360 D/A - converter from the mains supply and contact your dealer.



13 Specification

General		
Nominal voltage	Model 100-240V Model 220V/60Hz	100 - 240 V, 50-60Hz 220 V, 60Hz
Nominal consumption		200 W
Consumption	Standby	<0.5 W
D/A converter		
Sensitivity	(optional) SPDIF, AES/EBU	0.3 - 5 V
	USB, Network	0.4 - 2.5 V
Impedance	SPDIF	75 Ω
	AES/EBU	110 Ω
Output		
Frequency response		DC - 200 kHz
Output voltage	Balanced	4 Vrms
	Unbalanced	2 Vrms
Peak output current		0.2 A max.
Attenuation	Volume control	-79 to 0 dB
Output impedance	Balanced	10 Ω
	Unbalanced	5 Ω
THD+N		<0.0003 %
Spot noise		< -140 dBV/ $\sqrt{\text{Hz}}$
Dimensions		
Dimensions		430 x 350 x 142 mm
Weight		ca. 10 kg

Technical specifications are subject to change without prior notification.



14 Dimensions

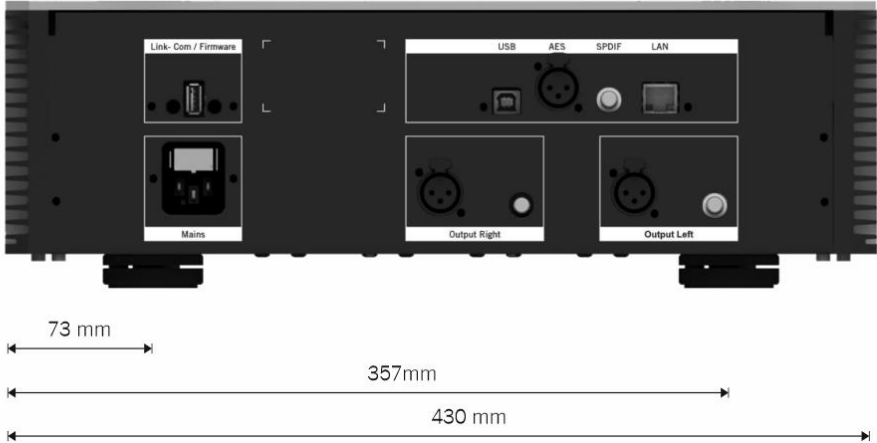
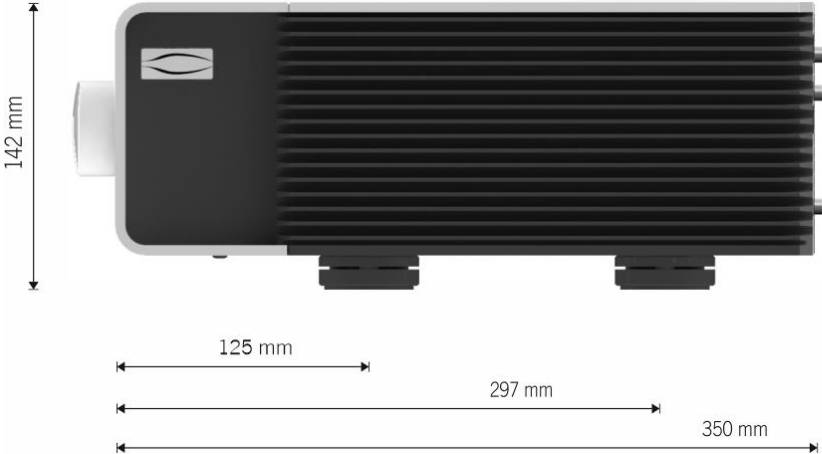

Spemot AG
Industriestrasse 70
CH-4657 Dulliken

www.soulution-audio.com
info@soulution-audio.com



part.no. 92259